

VENT AXIA SENTINEL KINETIC MVHR UNIT

SUITABLE FOR PROPERTIES UP TO 80m²

- **Manufactured in the UK**
- **Building Regulations Part F compliant**
- **SAP Appendix Q Eligible**
- **Energy savings trust best practice compliant**
- **Compact size - fits in a 600mm x 300mm kitchen cupboard (V and B models)**



Optional LCD remote controller



Optional RF boost switch

- Up to 92% heat recovery whilst controlling condensation
- Optional, programmable Summer bypass
- Cooker Hood version available
- Left or right hand installation (V, B and BH models)
- Horizontal and/or vertical duct outlets
- Integrated digital controller for simple and accurate commissioning
- Light weight for easy installation
- External condensate connection
- Plug and play controls; Humidistat, Vent-Wise, Wireless remote
- BMS connectivity
- LS inputs. (Light switch)
- Volt-free inputs
- Self diagnosis for simplified fault finding
- Multiple switching options: Light switch, PIR, Humidistat etc
- Adjustable delay on/delay off timer



VentRite
Unit 163
315 Chiswick High Road
London W4 4HH

Tel: 0845 467 9197
Info@VacAndVent.co.uk

PERFORMANCE

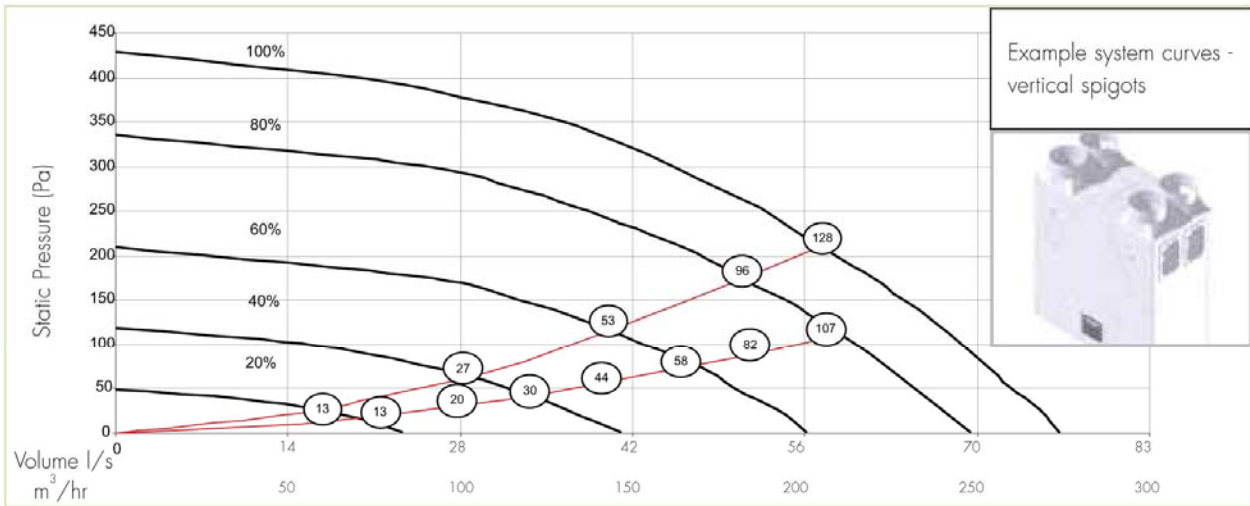

(X) wattage (both motors)

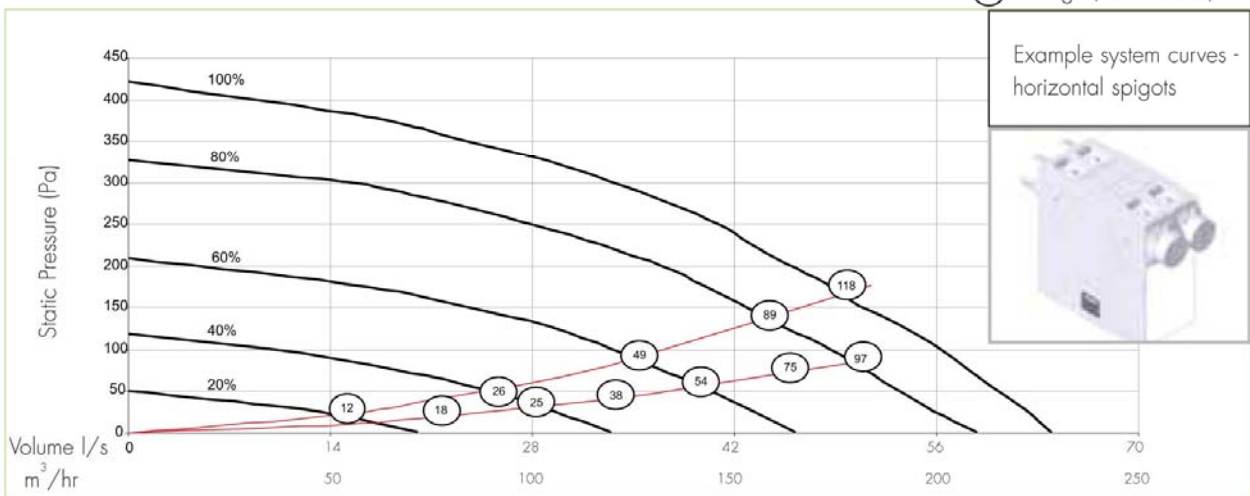

Flow, l/s	Test mode	Octave band, Hz, dB SWL								SPL dBA@ 3m
		63	125	250	500	1K	2K	4K	8K	
10	Supply	47.8	40.2	38.0	31.1	28.2	22.1	23.6	30.9	21.4
	Extract	47.0	38.7	36.0	29.9	25.0	22.4	23.3	30.8	20.6
	Breakout	43.6	36.2	37.4	30.9	27.4	23.3	24.2	31.4	18.6
20	Supply	54.0	46.6	50.2	44.5	44.4	38.3	28.8	31.9	31.2
	Extract	46.8	40.5	34.6	34.2	34.6	25.9	23.7	30.3	22.9
	Breakout	45.9	39.9	40.6	35.7	33.5	28.4	25.3	31.2	21.3
30	Supply	58.1	54.5	57.6	52.2	51.7	47.6	38.6	35.8	38.5
	Extract	47.6	46.2	38.7	41.3	42.8	33.9	26.4	30.5	28.4
	Breakout	45.2	42.4	48.2	40.8	37.7	35.2	30.0	31.1	25.2
40	Supply	65.2	58.4	62.3	58.0	56.5	52.5	44.1	41.4	43.6
	Extract	53.5	53.0	44.0	47.7	48.1	39.7	31.5	31.5	33.5
	Breakout	50.9	47.6	47.4	48.1	42.5	40.8	36.3	34.4	29.3
50	Supply	66.4	63.2	66.3	62.5	61.7	57.4	50.0	47.8	48.3
	Extract	64.2	55.2	48.0	50.9	52.1	44.5	35.9	35.0	37.2
	Breakout	55.0	51.0	51.3	51.6	46.9	46.0	42.0	38.3	33.2

V&B models

Weight : 15kg

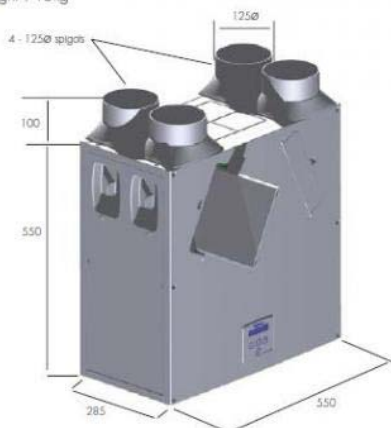

An easily accessible heat recovery cube protected by two removable EU3 filters. Two Lo-Carbon Energy Saving EC DC fans ensure long life (typically over double the life of AC motors) and lowest possible energy use. Fully insulated construction with built in condensation drain. Fitted with 125mm spigots. Specifically designed for new build homes with a high level of insulation. Lo-Carbon Sentinel Kinetic meets the latest requirements of the Building Regulations Document F 2010 for whole house system ventilation: System 4. Continuous mechanical supply and extract with heat recovery.